

Toaleta myjąca

Instrukcja montażu

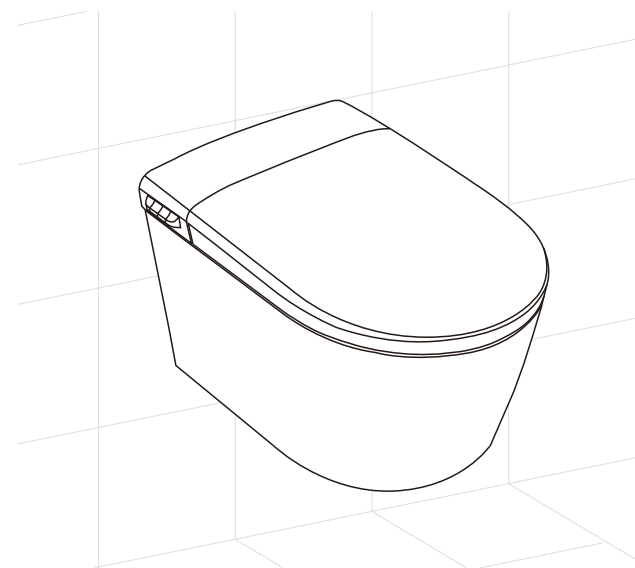

**GEFAHR**

Gefahr eines elektrischen Schlags

Das Gerät darf nur an Steckdosen oder Festanschlüssen mit Schutzerdung betrieben werden.

ZAGROŻENIE

Porażenie prądem elektrycznym

Urządzenie należy podłączyć do gniazdka elektrycznego z uziemieniem.

DANGER

Risque de décharge électrique

L'appareil ne doit être raccordé qu'à des prises électriques ou des branchements fixes avec mise à la terre.

PERICOLO

Pericolo di scossa elettrica

L'apparecchio può essere utilizzato esclusivamente con prese elettriche o allacciamenti fissi provvisti di messa a terra.

GEVAAR

Gevaar van een elektrische schok

Het apparaat mag alleen aan stopcontacten of vaste aansluitingen met randaarding worden gebruikt.

PELIGRO

Peligro de descarga eléctrica

El dispositivo debe utilizarse solamente en salidas de corriente o conexiones fijas con puesta a tierra de protección.

PELIGRO

Perigo de choque eléctrico

O aparelho só pode ser utilizado em tomadas ou ligações xas com ligação à terra de protecção.

FARE

Fare for elektrisk stød

Enheden må kun anvendes på stikdåser eller fastopkoblede forbindelser med arbejdsjording.

FARE

Fare for elektrisk støt

Apparatet skal kun drives i stikkontakter eller faste tilkoblinger med jordet ledning.

VAARA

Sähköiskun vaara

Laitetta saa käyttää vain sellaisissa pistorasioissa tai kiinteissä liitännöissä, jotka on maadoitettu.

危険

电击危险

该设备只能在有接地保护的插座上操作。

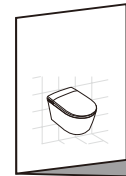
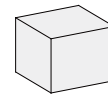
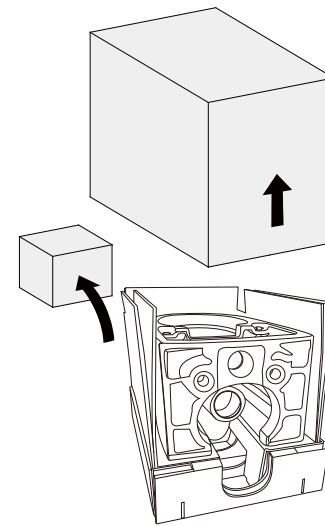
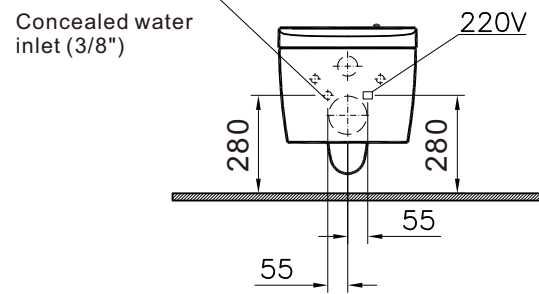
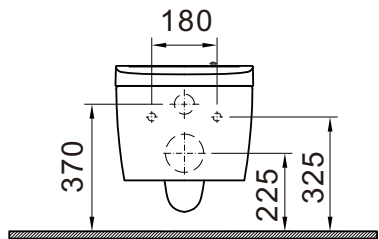
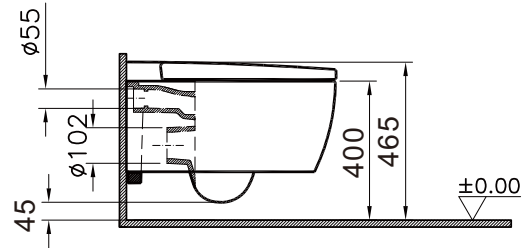
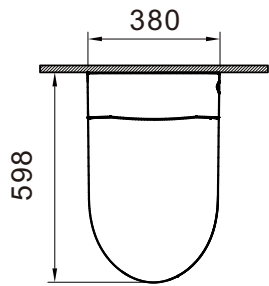

a



b



c



d



e



f



g

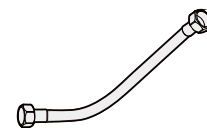

h



j



k

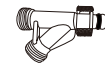

m



o

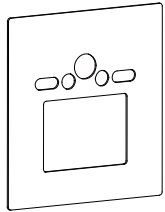

n

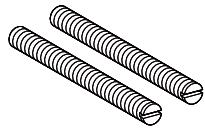

p

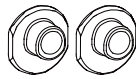

q



r



s

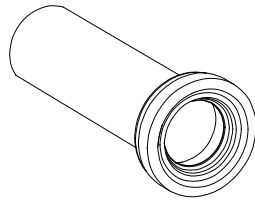

t

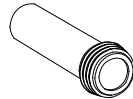

u

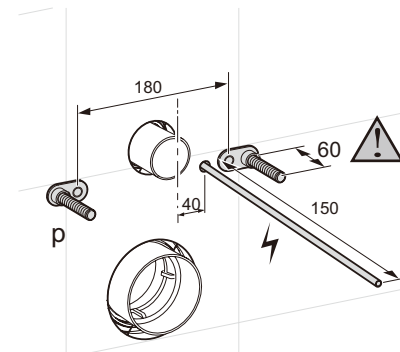
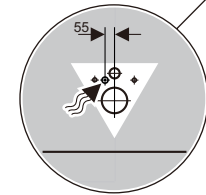
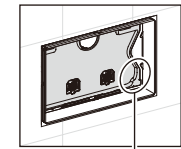
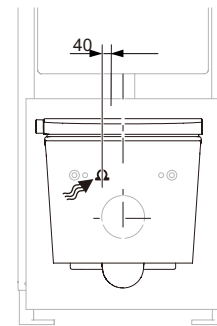
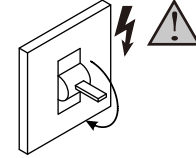
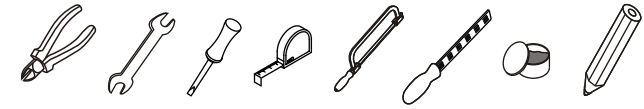



1

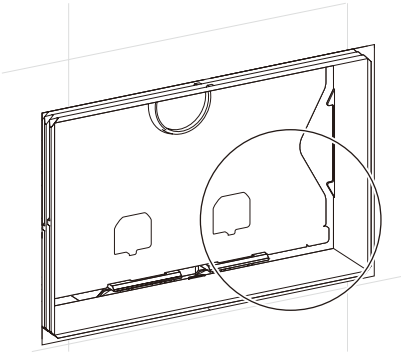

2

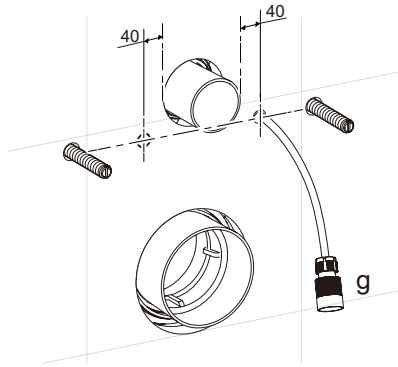
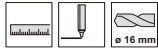

3

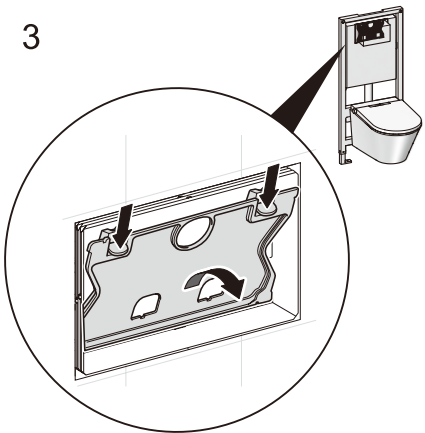

4

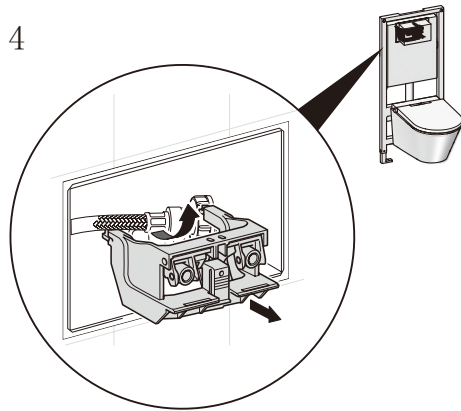

5

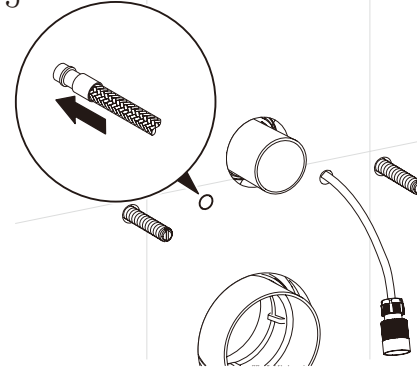

6

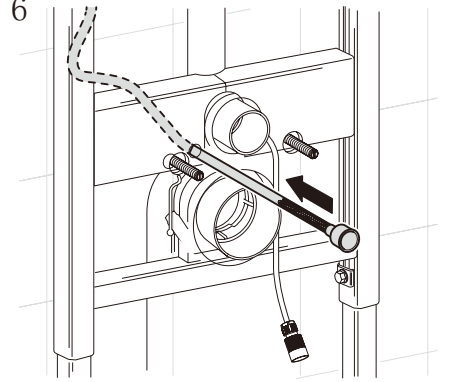

7

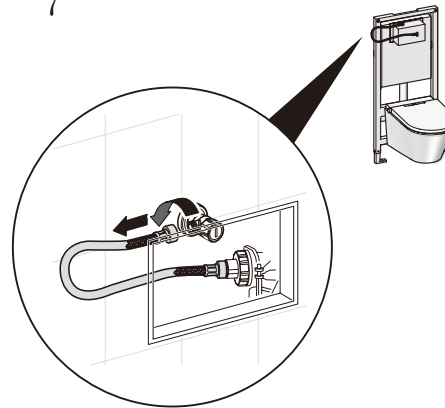

8

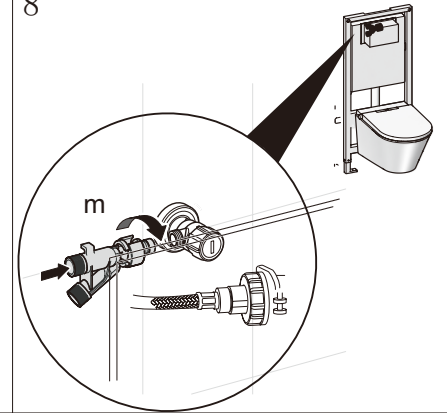

9

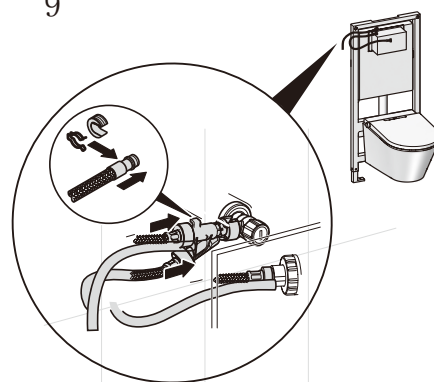

2

1

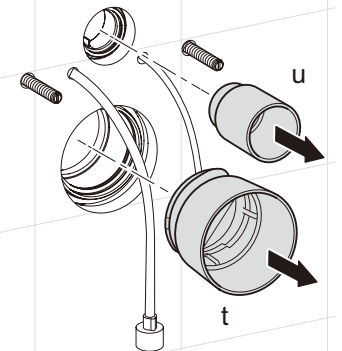

2

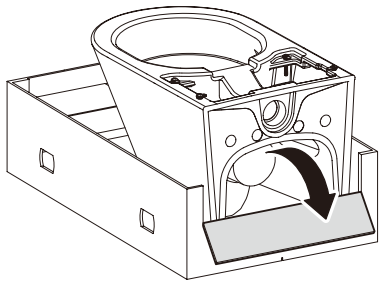

3

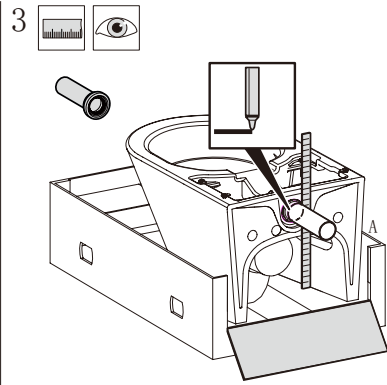

4

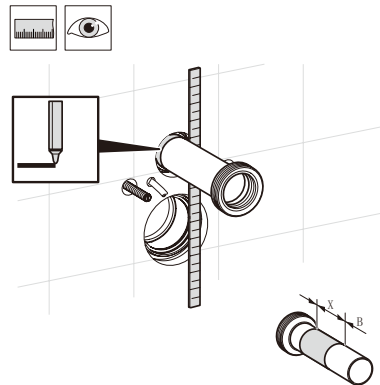

5

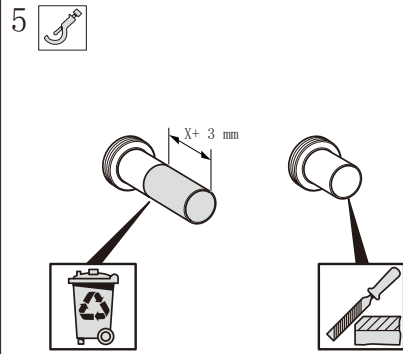

6

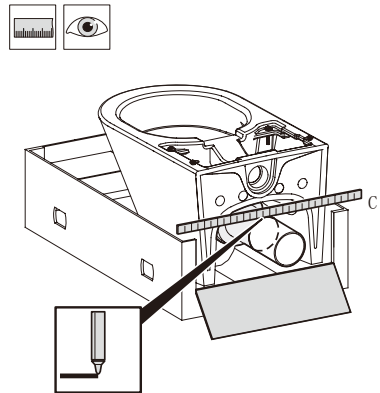

7

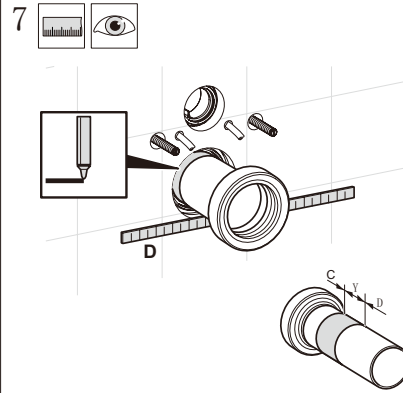

8

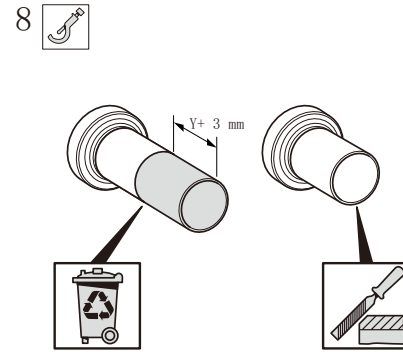

9

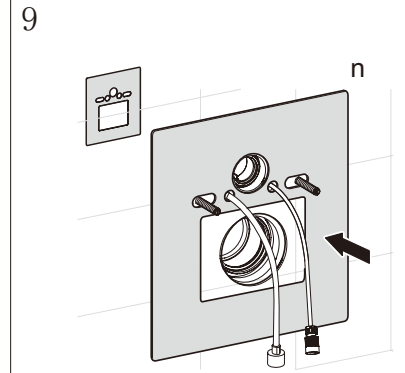

10

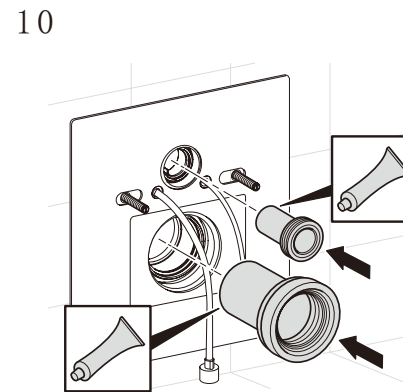

11

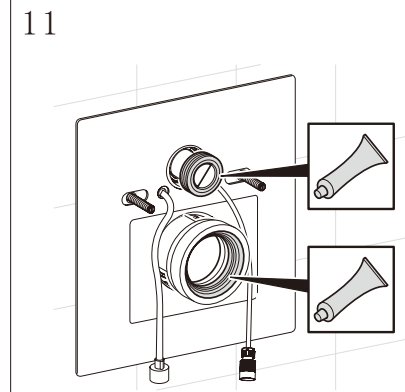

12

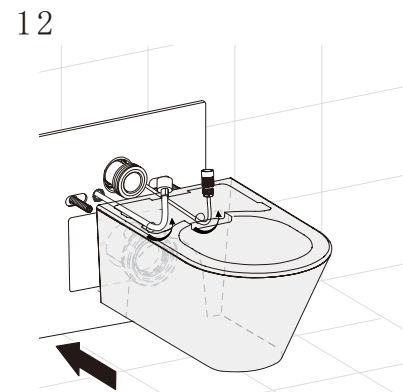

13

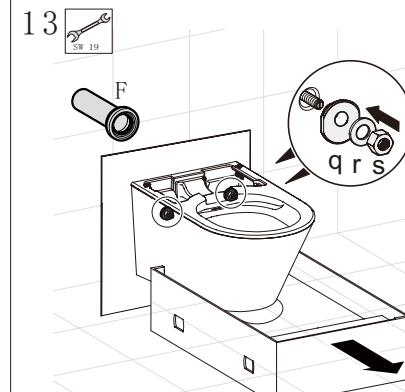

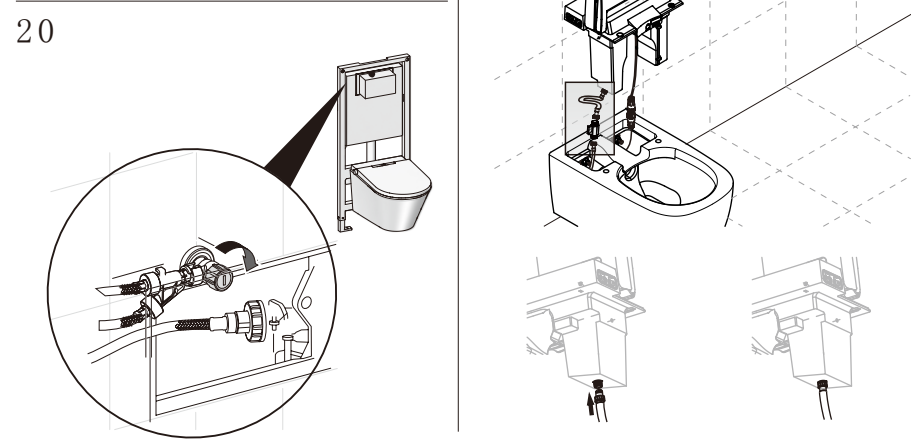
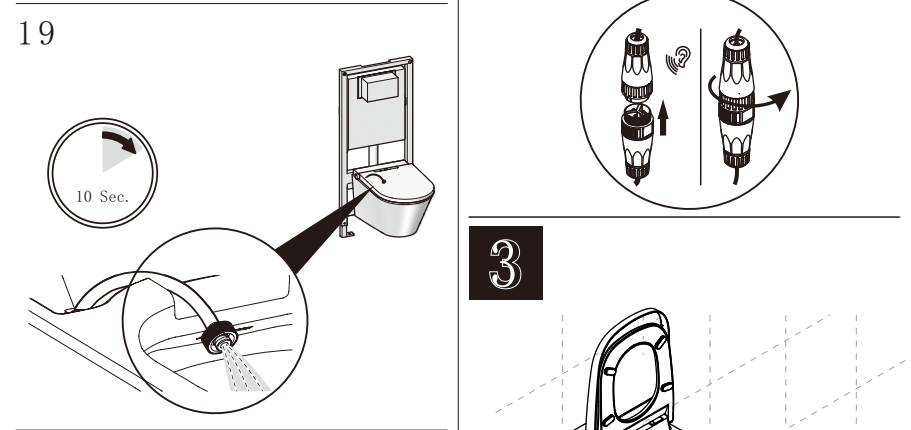
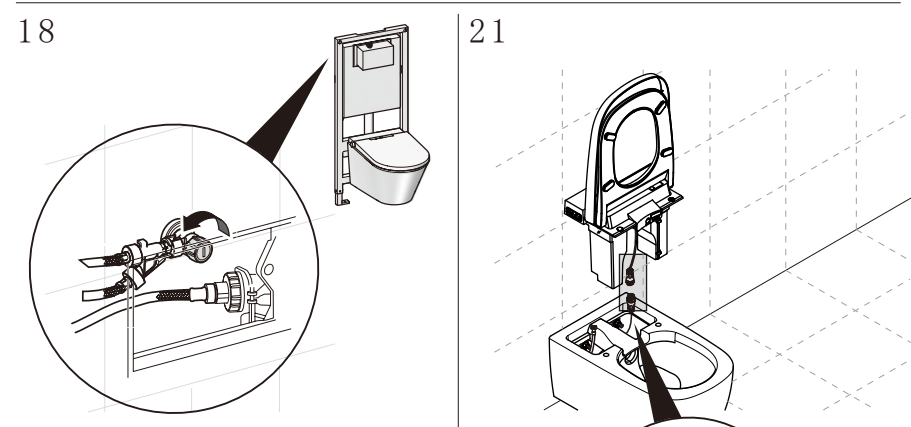
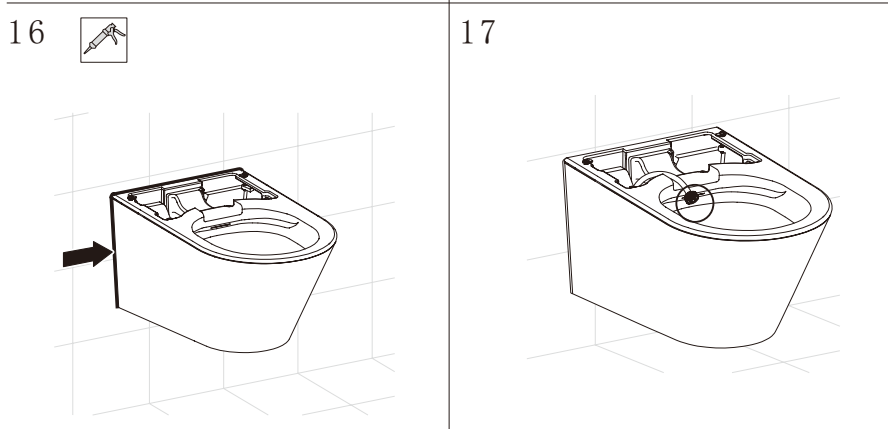
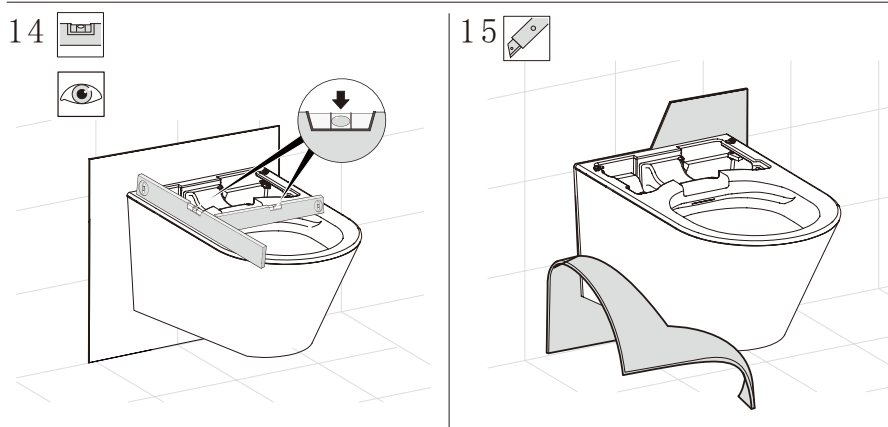

4

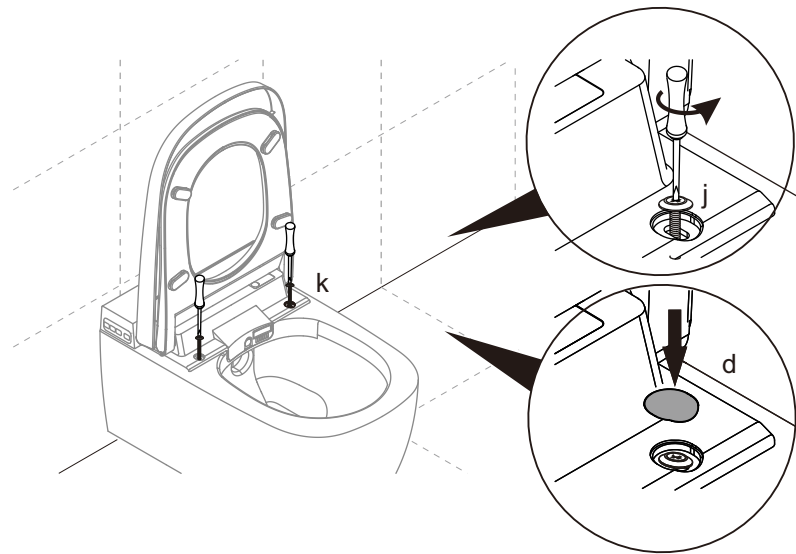
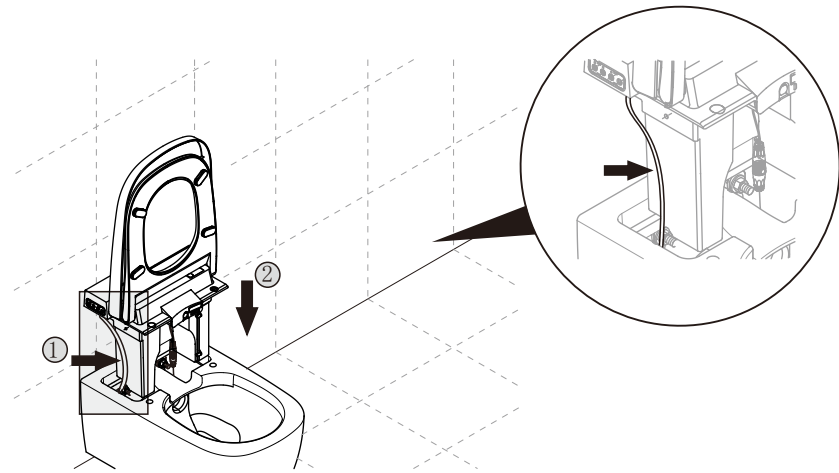

5

